

TD4SPA/A

Diesel / standby generator sets

42 kVA, 400 V, 50 Hz



TECHNICAL DATA

• Prime Power	42 kVA / 33,6 kW
• Standby Power	46,2 kVA / 37 kW
• Voltage	400 V
• Frequency	50 Hz
• Rated current	63 A
• Power factor, cos φ	0,8
• Fuel tank capacity	160 l
• Fuel consumption at 75% load	8,0 l/h
• Weight	840 kg

ENGINE

• Manufacturer	Perkins
• Model	1103C - 33TG3
• Fuel	Diesel
• Power at 1500 RPM.	46,5 kW
• Rotation speed	1500 min ⁻¹
• Cubic capacity	3300 cm ³
• Number of cylinders	3
• Bore / Stroke	105 / 127 mm
• Compression ratio	18,23 : 1
• Cooling system	Liquid cooled
• Cooling system capacity	10,2 l
• Lubricating oil capacity	8,3 l
• Starter	12 V / 3 kW
• Alternator	12 V / 65 A
• Battery	12 V / 80 Ah

ALTERNATOR

• Number of poles	4
• Type	Brushless
• Voltage regulator	Automatic (AVR)
• Voltage range	+1%, -1%
• Protection level	IP23
• Insulation class	H



TD45P/A

Diesel / standby generator sets

42 kVA , 400 V, 50 Hz

EQUIPMENT

	P	PA		P	PA
Voltmeter (L-L, L-N)	<input checked="" type="checkbox"/>	<input checked="" type="checkbox"/>	Standby battery charger	<input checked="" type="checkbox"/>	<input checked="" type="checkbox"/>
Frequency meter	<input checked="" type="checkbox"/>	<input checked="" type="checkbox"/>	Automatic fuel pump system	<input checked="" type="checkbox"/>	<input type="checkbox"/>
Working hours counter	<input checked="" type="checkbox"/>	<input checked="" type="checkbox"/>	Oil pressure indicator	<input type="checkbox"/>	<input type="checkbox"/>
Fuel level indicator	<input checked="" type="checkbox"/>	<input checked="" type="checkbox"/>	Coolant temperature indicator	<input type="checkbox"/>	<input type="checkbox"/>
Automatic circuit breaker	<input checked="" type="checkbox"/>	<input checked="" type="checkbox"/>	Earth fault device	<input type="checkbox"/>	<input type="checkbox"/>
Protection from a low oil pressure / level	<input checked="" type="checkbox"/>	<input checked="" type="checkbox"/>	Automatic transfer switch panel	<input type="checkbox"/>	<input type="checkbox"/>
Protection from engine overheating	<input checked="" type="checkbox"/>	<input checked="" type="checkbox"/>	Engine coolant heater	<input type="checkbox"/>	<input type="checkbox"/>
Emergency stop push button	<input checked="" type="checkbox"/>	<input checked="" type="checkbox"/>	Engine oil heater	<input type="checkbox"/>	<input type="checkbox"/>
Terminals for cable connection	<input checked="" type="checkbox"/>	<input checked="" type="checkbox"/>	Manual engine oil pump	<input type="checkbox"/>	<input type="checkbox"/>
Heavy duty connector for quick ATS/AMF panel connection	<input checked="" type="checkbox"/>	<input checked="" type="checkbox"/>	Earthing spike	<input type="checkbox"/>	<input type="checkbox"/>
Engine glow plugs	<input checked="" type="checkbox"/>	<input checked="" type="checkbox"/>	Anticondensation heater	<input type="checkbox"/>	<input type="checkbox"/>
Residential silencer	<input checked="" type="checkbox"/>	<input checked="" type="checkbox"/>	GSM modem for remote control / monitoring	<input type="checkbox"/>	<input type="checkbox"/>
Battery power switch	<input checked="" type="checkbox"/>	<input checked="" type="checkbox"/>	Additional fuel tank	<input type="checkbox"/>	<input type="checkbox"/>
One key system	<input checked="" type="checkbox"/>	<input checked="" type="checkbox"/>	Protective bath for fuel and engine fluids	<input type="checkbox"/>	<input type="checkbox"/>
Ammeter (L1, L2, L3)	<input checked="" type="checkbox"/>	<input checked="" type="checkbox"/>			

- Standard
- Optional
- Not available

OTHER INFORMATION

- Warranty **24 months**.
- Electrical power according to ISO 8528.

DIMENSIONS

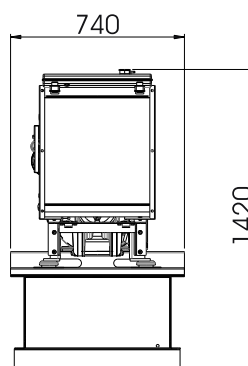
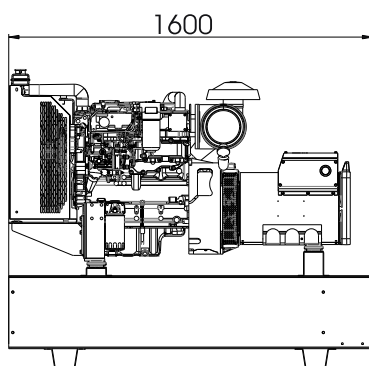

JSC "Generga"
 Savanorių str. 192
 LT - 44151 Kaunas, Lithuania
 Phone: +370 37 455456
 Fax: +370 37 455456
 E-mail: info@generga.com
www.generga.com

The information presented in this document is subject to change without prior notice.

Distributed by

