

## TECHNICAL DATA

• Prime Power	20 kVA / 16 kW
• Standby Power	22 kVA / 17,6 kW
• Voltage	400 V
• Frequency	50 Hz
• Rated current	29 A
• Power factor, cos $\varphi$	0,8
• Fuel tank capacity	70 l
• Fuel consumption at 75% load	4,0 l/h
• Weight	474 kg

## ENGINE

• Manufacturer	Perkins
• Model	404D – 22G
• Fuel	Diesel
• Power at 1500 RPM.	20,6 kW
• Rotation speed	1500 min <sup>-1</sup>
• Cubic capacity	2216 cm <sup>3</sup>
• Number of cylinders	4
• Bore / Stroke	84 / 100 mm
• Compression ratio	23,3 : 1
• Cooling system	Liquid cooled
• Cooling system capacity	7,0 l
• Lubricating oil capacity	9,75 l
• Starter	12 V / 2 kW
• Alternator	12 V / 65 A
• Battery	12 V / 80 Ah

## ALTERNATOR

• Manufacturer	Stamford
• Number of poles	4
• Type	Brushless
• Voltage regulator	Automatic (AVR)
• Voltage range	+1,5 %, -1,5 %
• Protection level	IP 23
• Insulation class	H

# TD20P/A

Diesel / standby generator sets  
 20 kVA, 400 V, 50 Hz

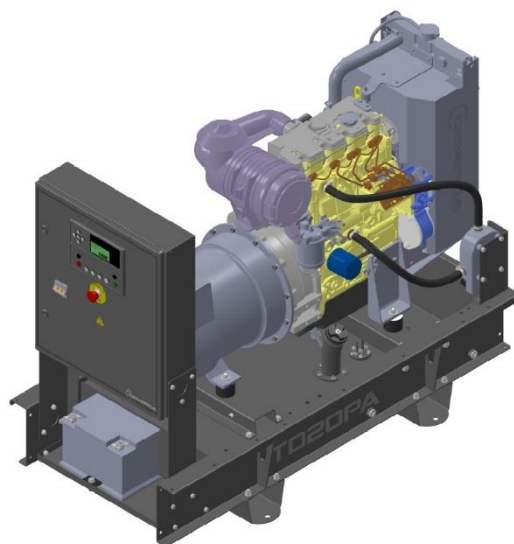



## EQUIPMENT

	P	PA		P	PA
Voltmeter (L-L, L-N)	✓	✓	Standby battery charger	✗	✓
Frequency meter	✓	✓	Automatic fuel pump system	✗	□
Working hours counter	✓	✓	Oil pressure indicator	□	□
Fuel level indicator	✓	✓	Coolant temperature indicator	□	□
Automatic circuit breaker	✓	✓	Earth fault device	□	□
Protection from a low oil pressure / level	✓	✓	Automatic transfer switch panel	□	□
Protection from engine overheating	✓	✓	Engine coolant heater	□	□
Emergency stop push button	✓	✓	Engine oil heater	□	□
Terminals for cable connection	✓	✓	Manual engine oil pump	□	□
Heavy duty connector for quick ATS/AMF panel connection	✓	✓	Earthing spike	□	□
Engine glow plugs	✓	✓	Anticondensation heater	□	□
Residential silencer	✓	✓	GSM modem for remote control / monitoring	□	□
Battery power switch	✓	✓	Additional fuel tank	□	□
One key system	✓	✓	Protective bath for fuel and engine fluids	□	□
Ammeter (L1, L2, L3)	✗	✓			

## OTHER INFORMATION

Warranty **24 months**  
Electrical power according to **ISO 8528**

- ✓ Standard
- Optional
- ✗ Not available

## DIMENSIONS

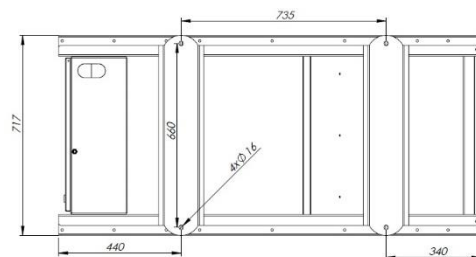
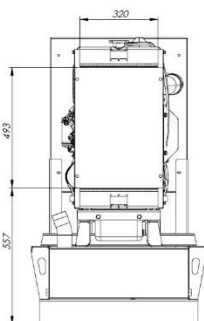
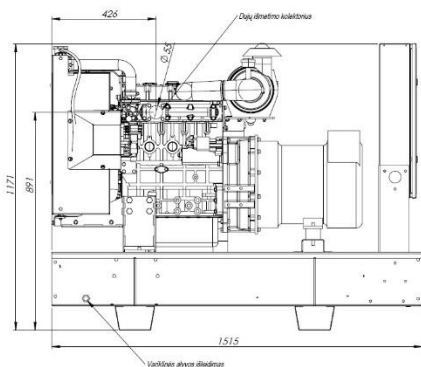

UAB "Generga"  
Energetiku str. 17  
LT - 52368 Kaunas, Lithuania  
Phone: +370 37 455456  
E-mail: info@generga.com  
[www.generga.com](http://www.generga.com)

Distributed by